

# **XDS PRO4 Satellite Receiver**



## **User's Guide**

**Copyright © 2006 X-Digital Systems, Inc.**

All rights reserved. No part of this document may be reproduced or transmitted in any form or by any means, electronic or mechanical, including but not limited to photocopying, recording, or by any information storage and retrieval system without the prior written permission from X-Digital Systems, Inc.

**Warning and Disclaimer**

This document is intended to provide information about installing and operating the “XDS-PRO4 DVB Satellite Receiver”. Every effort has been made to make this document as complete and accurate as possible, but no warranty or fitness is implied. The information is provided on an “as is” basis and X-Digital Systems shall have neither liability nor responsibility to any person or entity with respect to any loss or damages arising from the information contained in this document.

**Acknowledge of Trademarks**

Any product or corporate names used herein may be trademarks or registered trademarks, and are only used for identification and explanation, without intent to infringe. Any terms mentioned or used that are known trademarks or service marks have been appropriately capitalized and italicized. X-Digital Systems, Inc. cannot attest to the accuracy of this information. Use of a term in this manual should not be regarded as affecting the validity of any trademark or service mark.

**Printed in the United States of America**

X-Digital Systems, Inc.  
9727 Pacific Heights Blvd.  
Suite 200  
San Diego, CA 92121

**Patent Pending**

X-Digital Systems, Inc., DVB Satellite Receiver – Patents Pending



**Warning!**

Approved external telecom power cross protection must be incorporated into the final installation in accordance with Annex NAC of UL/CSA standard 60950-1. Failure to comply may result in a fire or electric shock hazard and will void regulatory compliance certification.

THIS DEVICE COMPLIES WITH PART 15 OF THE FCC RULES. OPERATION OF THIS DEVICE IS SUBJECT TO THE FOLLOWING TWO CONDITIONS: (1) THIS DEVICE MAY NOT CAUSE HARMFUL INTERFERENCE, AND (2) THIS DEVICE MUST ACCEPT ANY INTERFERENCE RECEIVED, INCLUDING INTERFERENCE THAT MAY CAUSE UNDESIRED OPERATION.

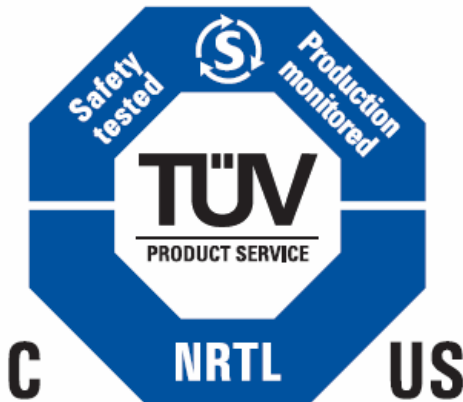

# TABLE OF CONTENTS

1	INTRODUCTION .....	5
1.1	Important Information.....	5
1.2	Hardware Upgradeability.....	5
1.3	Hardware Versatility.....	5
1.4	Network Management System.....	6
2	GETTING STARTED .....	7
2.1	Unpacking the Receiver.....	7
2.1.1	List of Contents.....	7
2.2	Safety Precautions.....	7
2.2.1	Excessive Temperature .....	7
2.2.2	Proper Ventilation.....	8
2.2.3	Heat, Humidity, and Dust .....	8
2.2.4	Power Cord Cabling.....	8
2.2.5	Proper Grounding.....	8
2.2.6	Circuit Overloading .....	8
2.2.7	Foreign Objects.....	9
2.3	Physical Installation of the Receiver.....	9
2.3.1	Rack Mounting the Receiver .....	9
2.3.2	Uneven Loading of Rack .....	9
2.4	Connecting the Receiver to a Satellite Dish .....	9
2.4.1	DC Voltage Requirement.....	10
2.4.2	Warnings About Shorting DC.....	10
3	QUICK START .....	11
3.1	General Guidelines.....	11
4	FRONT PANEL OPERATIONS.....	12
4.1	Status LEDs .....	12
4.1.1	The Power LED .....	12
4.1.2	The Signal LED .....	12
4.1.3	The Update LED.....	12
4.1.4	The Fault LED .....	12
4.2	The LCD Display and User Interface .....	13
	The Main Menu Options.....	13
4.2.1	The Status Sub-Menus .....	14
4.2.2	The SETUP Sub-Menus.....	15
4.2.2.1	The SETUP:NETWORK Sub-Menus.....	16
4.2.2.2	The SETUP:TUNER Sub-Menus .....	17
4.2.3	The AUDIO PORTS Sub-Menus .....	18
4.2.3.1	The AUDIO PORTS:SETUP Sub-Menus .....	19
5	ETHERNET SETUP.....	21
5.1	Connecting the Cables .....	21
5.2	Using DHCP or Static IP Addresses.....	21
5.3	Assigning a TCP/IP Address .....	21
5.4	Assigning a Subnet Mask.....	22
5.5	Assigning a Default Gateway .....	22
5.6	Proxy Server Configuration .....	22

5.7	DNS Server Configuration.....	22
6	RECEIVER WEB INTERFACE .....	23
6.1	The General Menu .....	23
6.1.1	The Status Tab .....	23
6.1.2	The Tuner Tab.....	24
6.1.3	The Setup Tab.....	25
6.1.4	The Relays Tab .....	26
6.2	The Programming Menu .....	27
6.2.1	The Programs Tab.....	27
6.2.2	The Recordings Tab.....	28
6.3	The Content Menu .....	29
6.3.1	The Audio Tab .....	29
6.3.2	The Traffic Tab.....	29
6.3.3	The All Tab.....	30
7	AFFILIATE WEB INTERFACE .....	31
7.1	Accessing and Logging In .....	31
7.2	Play Scheduling .....	31
7.3	Changing the Relay Mappings.....	32
7.4	Changing the Receiver's Time Zone .....	32
8	MONITOR AND CONTROL INTERFACE .....	34
8.1	Setting up a Console Connection.....	34
8.2	Console Commands .....	35
9	SPECIFICATIONS.....	39
9.1	Receiver Interface Specification.....	39
9.2	Mechanical/Electrical Specification .....	39
9.3	Environmental Specifications .....	39
9.4	M&C Interface Connector Pin-Outs.....	40
9.5	Relay Outputs.....	41
9.6	Analog Audio Output.....	42
9.7	Analog Audio Input .....	43
9.8	Digital Audio Output .....	44
9.9	PAD/ASYNC Output Port .....	45
9.10	Ethernet Port .....	45
9.11	Modem (POTS) Port.....	45
9.12	RF Input Parameters .....	46

# 1 INTRODUCTION

Welcome to the future of digital audio for the radio industry. This User's Guide is your handbook for the X-Digital PRO4 digital audio receiver. This receiver is equipped to deliver multiple audio services in high quality digital audio for your radio station. It has been designed to make use of all the digital communication features of today, and to be upgraded to take advantage of the technologies of tomorrow.

## 1.1 Important Information

Throughout this guide, you will find icons designed to help you quickly spot important information:



### **Note!**

The note icon identifies information for the proper operation of your equipment, including helpful hints, shortcuts, or important reminders



### **Caution!**

The caution icon identifies information that requires careful attention in order to prevent equipment damage.



### **Warning!**

The warning icon identifies a procedure or practice that could result in personal injury if not performed correctly.

## 1.2 Hardware Upgradeability

X-Digital Systems, Inc. can upgrade its main control software and audio decoder algorithms over-the-air. This ensures that your receiver will always have the most up to the minute features and functionality.

## 1.3 Hardware Versatility

The XDS PRO4 can deliver audio received via satellite over any one of its four balanced output ports. Additionally, content can be received and stored locally for later use. This content can originate from a real time satellite broadcast, from a high speed satellite IP distribution channel, or can be retrieved via the Internet over the Ethernet port, if so configured.

## 1.4 Network Management System

The PRO4 satellite receiver has been specifically designed so that its output can be controlled via one central web application. This application is called the Network Management System, or NMS. From the NMS, network managers will be able to create play schedules consisting of radio programs and any combination of network, regional, or off-time commercial spots. The NMS will also coordinate file transfers to store sound, data, or hardware updates directly to the PRO4's internal hard drive. The NMS will also come equipped with an advanced event logging system ensuring that any technical problems will be accompanied by a full history so that causes of problems may be easily identified and eliminated.

## 2 GETTING STARTED

Please take a few minutes to read through the User's Guide prior to setting up and using the unit. If you are in a hurry, there is a Quick Start section below, but please be sure to consult this section at your earliest convenience.

### 2.1 Unpacking the Receiver

Upon receiving your PRO4 Receiver, ensure that all of the necessary parts have been included.

#### 2.1.1 List of Contents

Table 1 lists the items included in the PRO4 shipping box.

Item	Quantity
Receiver	1
Power Cord	1
Quick Start Guide	1
Installation Kit (Optional)	1

Table 1. Packaging List

### 2.2 Safety Precautions



**Caution!** The following sections provide a list of general hazards to be avoided for safe, reliable use of the PRO4 receiver.

#### 2.2.1 Excessive Temperature

The PRO4 receiver has been designed to operate safely and reliably in an ambient temperature of 0°C to 50°C. We expect the system to operate without a need for a fan in air conditioned locations. The fan will be electronically controlled via temperature sensor. This will allow the unit to operate under less than optimal conditions. However, once the receiver is located in a closed or rack environment, the ambient temperature may be greater than room temperature. Please take this into consideration when installing the receiver, making sure that the ambient temperature around the receiver does not exceed the temperature range 0°C to 50°C.

## 2.2.2 Proper Ventilation

Air vents on the side and rear of the receiver are provided to ensure proper air flow through the receiver unit. In order to ensure proper operation the PRO4 receiver should be located such that its ventilation is not impeded. In a rack environment, at least two inches on the sides and at least 5 inches in the rear should be provided. Proper ventilation will help ensure the receiver performs both safely and efficiently.

## 2.2.3 Heat, Humidity, and Dust

In order to avoid unnecessary internal damage, avoid placing the receiver next to external heat sources such as heaters, direct sunlight, heating ducts, etc. Also avoid locations of high humidity, dust, and vibration.

## 2.2.4 Power Cord Cabling

Avoid running the power cord across places of high traffic where it can be crimped or tripped over. Make sure the cords are securely fastened to both the wall outlet or power strip, and the back of the receiver. Do not place objects on or leaning against power cords.

## 2.2.5 Proper Grounding

When the receiver is installed, make sure that the antenna and coaxial cable are properly grounded to avoid static build up and voltage spikes which may occur due to lightning or other types of power surges. Proper earth grounding of the rack system should be maintained at all times, with special attention paid to any connections which go through power strips.



**Warning!** Make sure all power strips are properly grounded.

## 2.2.6 Circuit Overloading

The PRO4 receiver can draw up to 0.5 Amps at 120VAC as indicated on the back of the receiver. When adding the receiver to an already existing rack setup, take care to ensure the maximum current rating of the circuit is not exceeded.

## 2.2.7 Foreign Objects



**Warning!** Inserting *any* type of foreign object into the ventilation holes of the receiver can result in shock or serious injury of the operator.

If a foreign object is inserted into the receiver, immediately power down the receiver and contact X-Digital Systems technical support. Do not open the receiver, as doing so will void the receiver's warranty.

## 2.3 Physical Installation of the Receiver

The following section will guide you through the physical installation of the PRO4 receiver. The receiver should be installed in a standard 19-inch rack.

### 2.3.1 Rack Mounting the Receiver

The PRO4 receiver has been specifically designed to fit into a 19-inch rack. There are four screw holes provided on the front panel to directly mount the receiver in the rack. All four screws must be in place after installing the receiver.



**Caution!** Do not paint mounting ears; it hinders the grounding path from the receiver to the rack.

### 2.3.2 Uneven Loading of Rack

When installing the PRO4 receiver into a rack, make sure to place heavier pieces of equipment on the bottom and lighter pieces on the top.



**Caution!** Uneven loading may cause the rack to be unstable and hazardous.

## 2.4 Connecting the Receiver to a Satellite Dish

This section contains information required for connection your PRO4 receiver to a satellite hookup.

## 2.4.1 DC Voltage Requirement

You may need to have the PRO4 receiver supply DC voltage to either an LNB or a block down-converter (used after an LNA). If this is the case, the user must change the receiver's LNB on/off settings using the front panel display. For directions on how to use the front panel display, see Chapter 4 of this manual. If, however, you have another receiver that receives the L-Band version of the satellite signal (9500-14500MHz) then you may use a splitter with DC blocking circuitry to get the signal to the PRO4 receiver. In this case, set the LNB Voltage setting to off.

## 2.4.2 Warnings About Shorting DC



**Caution!** If the LNB Voltage mode is ON enabled, be careful not to short the signal. The voltage on this line is approximately +24V DC.

If the DC Voltage is shorted during installation, transient voltage may damage the Demodulator. In the case of a short, over-current protection circuitry will shut down the LNB supply. When this occurs, it is important to disconnect the receiver as soon as possible. If there is a “dead” short in the cable connecting the receiver to the satellite dish, the unit will not function properly. Remove the power cord from the rear of the unit and then check the cable connecting the receiver to the satellite dish to make sure it has not been damaged and is installed correctly. Finally, reinstall the power cord and proceed with unit setup.

## 3 QUICK START

This quick start is designed to get your XDS PRO4 receiver up and running as quickly as possible. Please refer to the full [Quick Start Guide](#) packaged with your receiver.

### 3.1 General Guidelines

Review this guide in its entirety before installing your XDS receiver. Also, follow these instructions before calling support.

- Make all satellite RF, data (LAN/WAN) and audio connections prior to applying AC power to the XDS receiver.
- It is strongly recommended to use a Phase Locked Loop (PLL) LNB for your new XDS receiver. The Local Oscillator (LO) stability of your LNB should not be above (worse than) 25kHz.
- If this XDS receiver is designated to supply DC power to the LNB at your dish, be sure to turn on the LNB voltage on the front panel menu AFTER the LNB is connected (See Satellite RF Connection section 1.2 on page 3).
- Your new XDS receiver is delivered with a parts kit that includes two 6-foot RG-6 cables and an L-band splitter that allows DC power to pass through one port.
- X-Digital Systems urges stations to use an Uninterruptible Power Supply (UPS) for the XDS receiver for equipment protection from power spikes or brownouts. Also consider lightning protection if you are located in an area susceptible to frequent lightning storms. Surge suppressors do not provide sufficient protection.

## 4 FRONT PANEL OPERATIONS

The PRO4 Receiver's Front Panel is equipped with a 128x64 pixel LCD display, four status LEDs; which indicate power, signal, update, and fault; and eight buttons: **1**, **2**, **3**, left(◀), right(▶), up(▲), down(▼), and **SET**. Using this interface a user may navigate through the PRO4's hierarchical menu to view, modify, and save receiver settings. The four status LEDs serve as a quick reference for the current state of the receiver.

### 4.1 Status LEDs

There are four status light emitting diodes, each indicating a specific property of the receiver. The following sections state their significance.

#### 4.1.1 The Power LED

The POWER LED is on when the unit is plugged in and there is no problem with the internal circuitry.

#### 4.1.2 The Signal LED

The SIGNAL LED is used to indicate when the receiver has locked onto a signal or not. If the signal LED is a solid green, the receiver is locked. Otherwise, the light will be off.

#### 4.1.3 The Update LED

The UPDATE led indicates a software download/upgrade is in progress. When it is blinking slowly (once per second), the download is in process. When it blinks fast (3x per second), an upgrade has been successful and the receiver should be rebooted at a convenient time (when audio is off air). The update LED will also be blinking if you haven't activated your receiver unit with the NMS. See the Quick Start guide in Chapter 3 for activation instructions.

#### 4.1.4 The Fault LED

The FAULT LED has three possible states. A red fault LED indicates that there is an active fault condition affecting the receiver. A green fault LED indicates that there is no active fault, but that there is either an active warning or a past fault in the fault history. An off fault LED indicates that all is well and there are no past faults detected. The STATUS menu (described below) will give you details as to which faults are active.

## 4.2 The LCD Display and User Interface

The PRO4 Receiver comes equipped with a 128x64 pixel LCD on its front panel which allows the user to view, modify, and save receiver settings. The navigation of the PRO4 receiver's menu hierarchy is simple:

- To cycle through the possible sub-menus, press the ◀ or ▶ buttons.
- To navigate into the currently selected sub-menu, press the ▼ button.
- To navigate back up into a higher level of the menu hierarchy, press the ▲ button.
- Once you have navigated to a menu which allows you to edit settings, use the ▲ and ▼ buttons to highlight options, and the set button, to pick an option.
- 

### The Main Menu Options

When the receiver's front panel is not being used, the idle screen featuring the X-Digital Systems<sup>1</sup> logo will be displayed. There are two important statistics displayed on this front logo screen: EB, *energy per bit relative to noise floor*, which is a quantitative measure of signal quality; and AG, *automatic gain*, which is an indicator of the signal level. Both of these quantities serve to describe the quality of the satellite signal and should be used as a guide when positioning the satellite dish. Better signals have better separation between the data and noise floor, and thus a higher EB. EB range is 0 - 18. The receiver will fade in and out below 5 dB Eb/No, and loose lock completely at around 3.5 dB. A powerful signal will have a high AG (indicating little amplification is required) while a weak signal will have a low AG (indicating unit is amplifying signal).

Once the ▼ button is pressed, the receiver will navigate into its main menu options. These options are: STATUS, SETUP, and AUDIO PORTS. Continually pressing ◀ (or ▶) will cycle through these three main menus. Pressing ▼ or **SET** will navigate into whichever one of these three options happen to be currently selected.

---

<sup>1</sup> The X-Digital logo may be replaced by your broadcaster's logo.

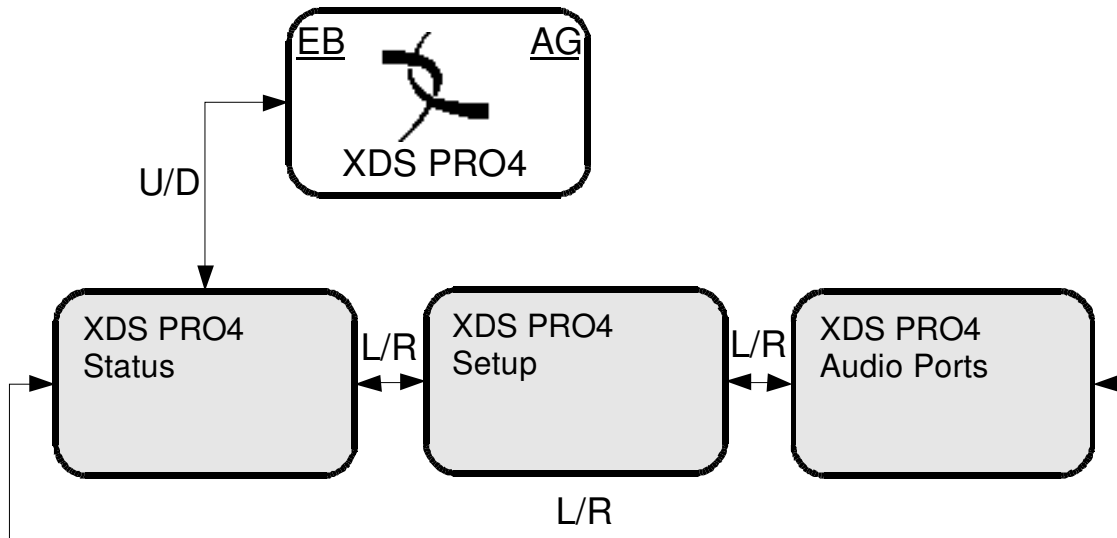

### 4.2.1 The Status Sub-Menus

From the Status menu, the user can navigate through five sub-menus, each of them offers various status-related information. From any of these sub-menus pressing the ▲ button will bring you back to the main menu options. The different sub-menus available in Status are:

- Active Faults: describes any active faults that may be affecting the receiver.
- Fault History: offers a list of past faults which may have occurred. Pushing 3 will clear the fault history.
- Environment: indicates whether the internal fans are functioning inside the unit, and the internal temperature of the receiver unit.
- Power Status: readings on the various voltage levels inside the receiver.
- Storage Status: gives an indication of the internal hard drive usage in the receiver.

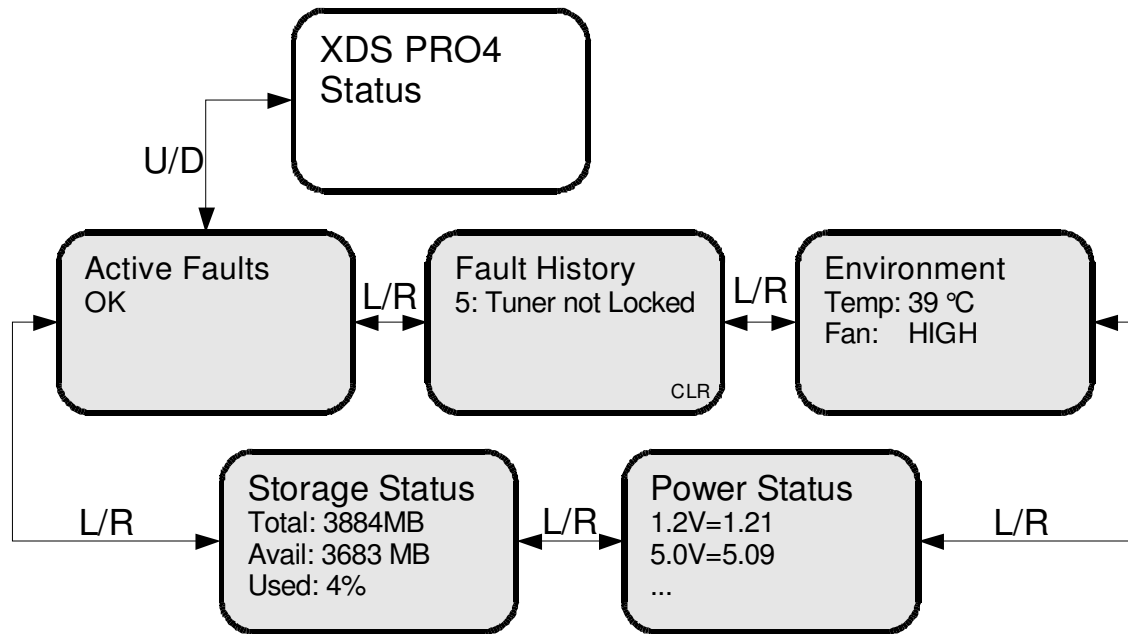

## 4.2.2 The SETUP Sub-Menus

By navigating from the Main Menu to Setup, the user reaches the Setup sub-menus. The different sub-menus available under Setup are:

- Serial Number: displays the receiver's serial number. Pressing the **3** quick key underneath "PWD" will display your receiver's affiliate site password.
- M&C Ports: displays M&C port settings.
- Network: pressing the ▼ will navigate into the Network sub-menus.
- Alarms: allows you to set the alarm mask as a hex value.
- Version: pressing **SET** in this menu will display the receiver's firmware version.
- Factory Defaults: pressing **SET** will offer you the option of resetting the receiver's settings to factory defaults. Press **1** to confirm or **3** to cancel. Reboot is required.
- Relays: allows you to switch any of the individual relay signals on Relay A or B to on. Press ▼ to choose which Relay port to edit, then press **SET** to modify which pins on the relay are activated. A '0' is an un-activated relay and a '1' is an activated relay. The first position is the Relay 1, the second position is Relay 2, and so on.
- Tuner: pressing the ▼ will navigate into the Tuner sub-menus.

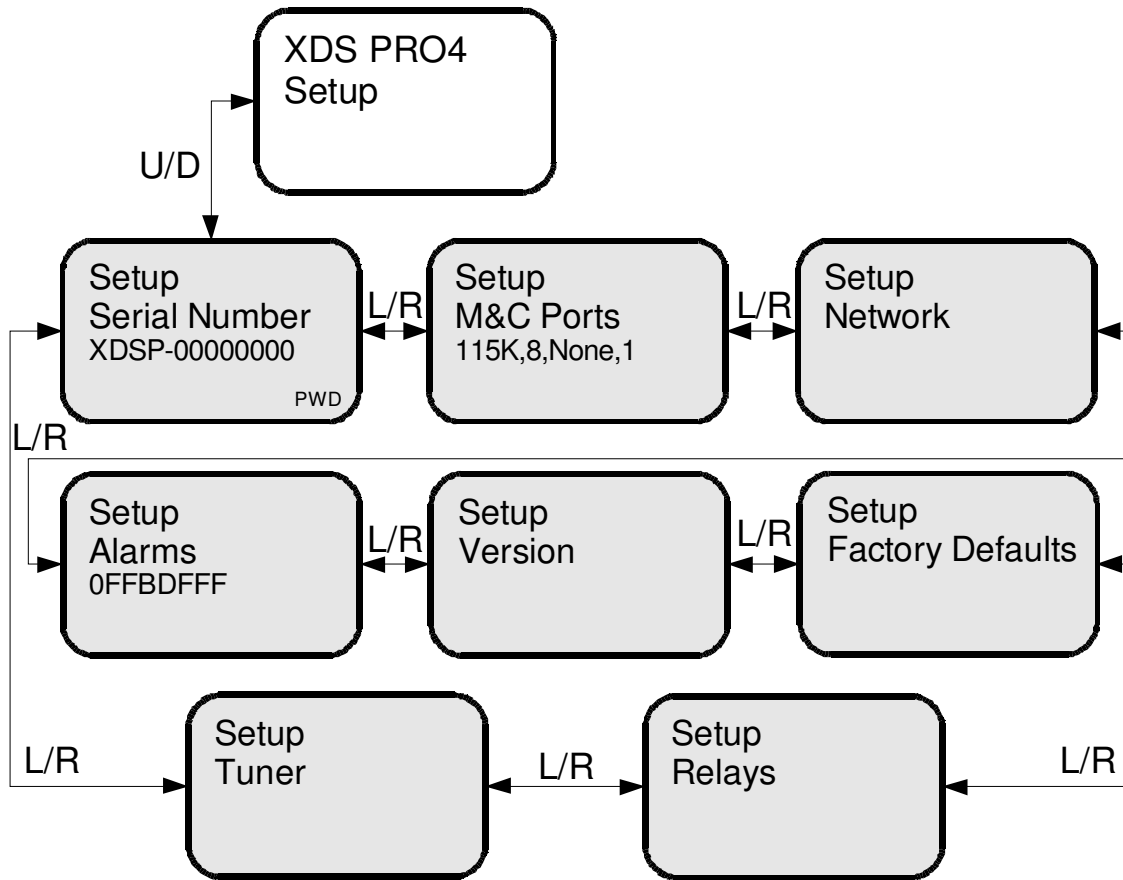

#### 4.2.2.1 The SETUP:NETWORK Sub-Menus

Starting from the Main Menu and navigating to Setup option and pressing ▼, and then navigating to Network option and pressing **SET**, a user will have access to the Network sub-menus. In these sub-menus, the receiver's network settings can be made. The network menu options include:

- DHCP (on or off): allows the user to specify a dynamic or static IP (on or off respectively).
- LAN IP Address: in the case of a static IP, this allows the user to specify the LAN IP address of the receiver.
- LAN Subnet Mask: allows the user to specify the LAN Subnet mask.
- WAN Address: specify the WAN IP address.
- WAN Subnet Mask: specify the WAN subnet mask.
- Gateway: allows the user to specify the default gateway to direct traffic to.
- Test: when **SET** is pressed, this menu offers the user two test options. Pressing **1** allows you to ping the internet to ensure the network connection is functioning, and pressing **2** tests the receiver's website to ensure it is functioning. Pressing **3** exits from the Test menu.

To modify any of these numeric values: use ◀ or ▶ to select which part of the IP to change. Make a digit larger using ▲, and to make a digit smaller using ▼. Press **SET** whenever you are done editing and want to commit a setting.

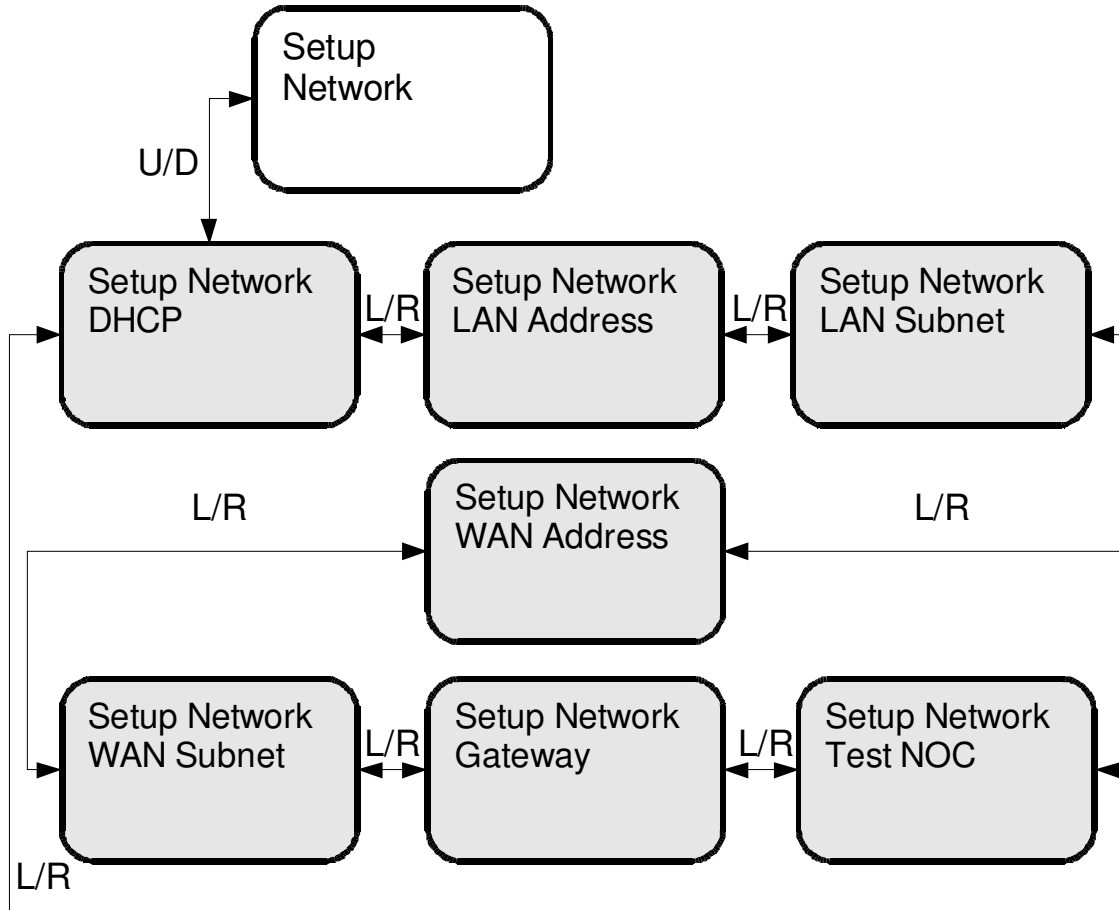

#### 4.2.2.2 The SETUP:TUNER Sub-Menus

Starting from the Main Menu and navigating to Setup option and pressing ▼, and then navigating to Tuner option and pressing **SET**, a user will have access to Tuner sub-menus. From this level the user can change various attributes of the receiver's tuner such as frequency, symbol rate, LNB frequency, LNB Power(on or off), and view the FEC setting. To change these options, the user navigates to the appropriate menu and presses **SET**, then uses the arrows to choose the new setting, and press **SET** again to commit.

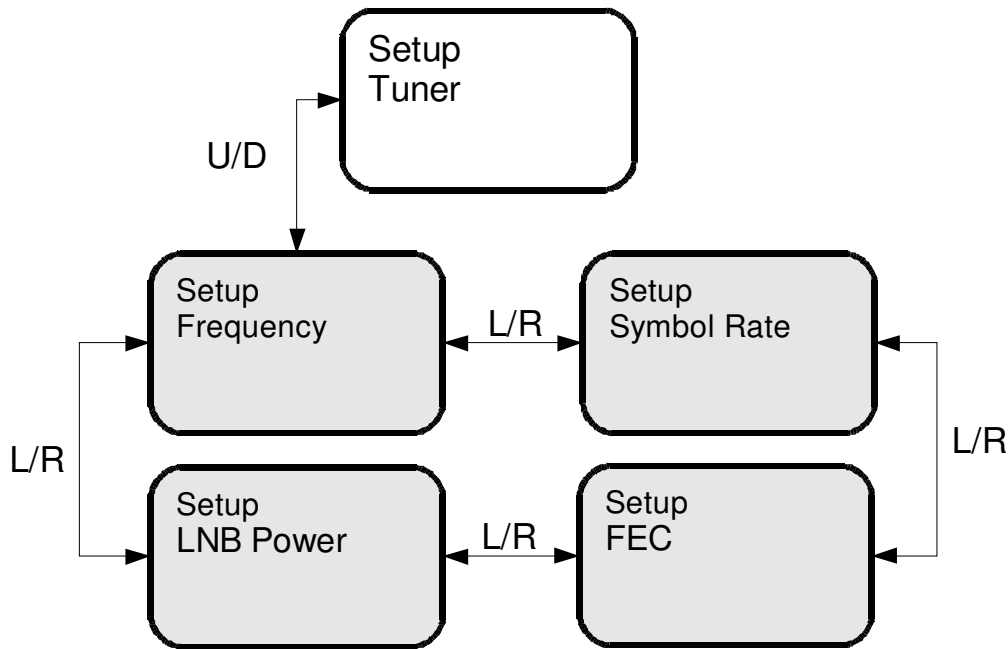

### 4.2.3 The AUDIO PORTS Sub-Menus

From the Audio Ports sub-menus, users can change the settings for each of the four ports as well as headphones port. To choose which of these five ports to modify scroll between them using ◀ or ▶ until the desired port is selected. Once the desired port is selected, pressing **1** will take you to the Station sub-menu where call letters for a station may be selected. Pressing **2** will take you to Programs sub-menu where a specific program may be chosen from a list using ▲ and ▼. Pressing **3** will navigate to the Spots sub-menu where specific radio spots may be chosen from a list, again using ▲ and ▼.

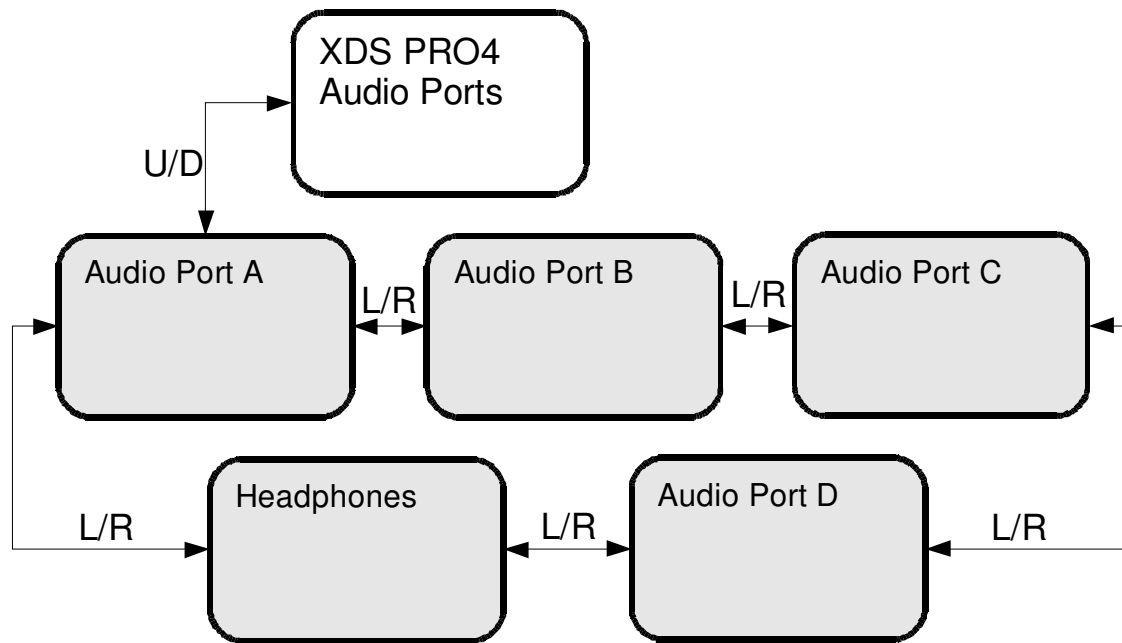

#### 4.2.3.1 The AUDIO PORTS:SETUP Sub-Menus

Each of the five audio ports (Audio Port A-D, and Headphones) have their own identical setup sub menus. From these menus, users may modify the station call number, the current program played on the audio port, the current commercial spot played on the audio port, and a couple miscellaneous audio settings (stereo or mono). These settings may only be changed if a red-cross symbol is *not* visible on the port's menu screen. If this symbol does appear, it means that this audio port is controlled automatically by the broadcaster, and that the user is unable to change any of these settings.

When the Station menu is selected by pressing **SET**, the receiver navigates to a screen where call letters can be selected in order by using **▲** and **▼** to choose a letter for the selected spot, **◀** and **▶** to choose which position in the name is selected for editing, and **SET** to commit the changes to the station's call letters. When Program or Spot menus are selected, the receiver will display a list of programs or spots respectively. Use **▲**, and **▼** to scroll through these lists, and use **SET** to select something from one of these lists. When the Settings menu is selected, the user can change the audio ports output mode from mono to stereo or vice versa. Again use the arrow keys and **SET** to accomplish this.

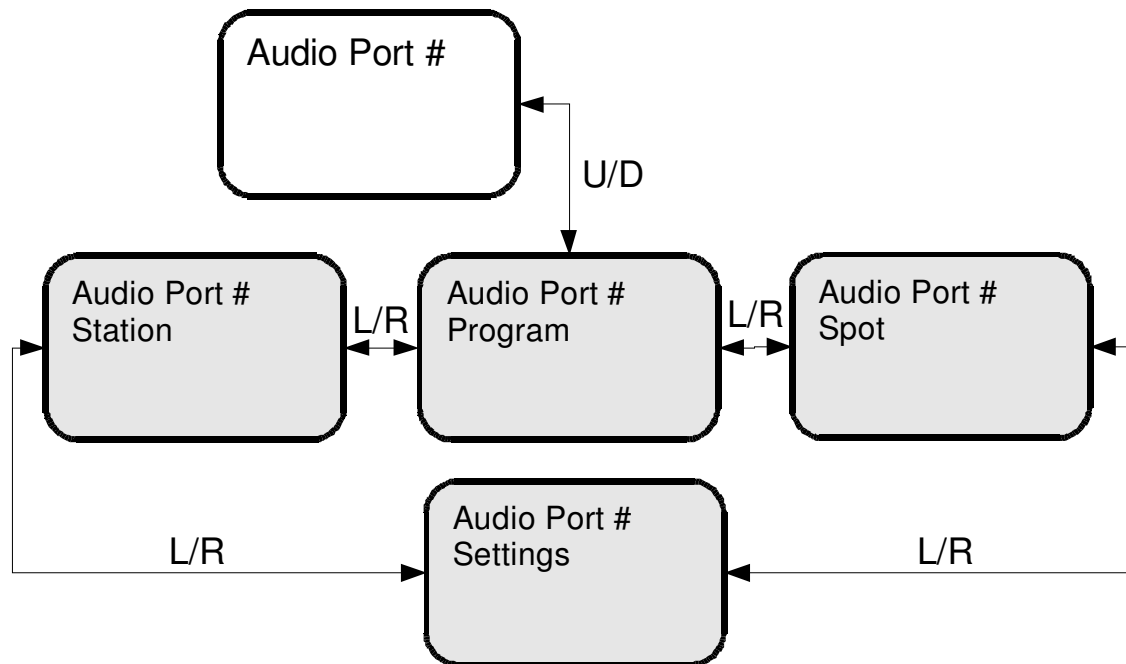

## **5 ETHERNET SETUP**

The XDS PRO4 Satellite Receiver is specifically designed to receive audio broadcasts via satellite transmissions. It is also equipped with an “internet” only mode in which it can receive audio data and receiver updates via its Ethernet port. For this feature to be functional, the receiver must be connected to a network router or directly connected to an internet connection. This portion of the User’s Guide will offer instruction on setting up your receiver’s connection to the internet. For all of the below settings, please contact your local network administrator for proper values.

### **5.1 Connecting the Cables**

The Ethernet port on the back of the receiver accepts non-crossover RJ-45 cables. Depending on your station’s internet connection, you will either connect a RJ-45 cable directly from a Cable or DSL modem box to the PRO4 receiver, or you will connect the cable from a network router to the receiver. In either case, ensure that the cable is squarely connected and that it clicks in when you connect it, so that it can not be removed without pressing the plastic release button on the end of the cable. Ensure that your internet connection is functioning before proceeding to the next steps.

### **5.2 Using DHCP or Static IP Addresses**

Dynamic Host Configuration Protocol, or DHCP, allows the network administrator to control the assignment of device IP assignment. If DHCP is on, the receiver will be assigned an IP address automatically by the network. The implications of this are that the IP of the receiver may change on a boot-up to boot-up basis. Turning DHCP will ensure that a static, or non-changing, IP is assigned to the receiver as opposed to a dynamic one determined at each startup of the receiver. For direction on turning DHCP on or off, refer to section 4.2.2.1.

### **5.3 Assigning a TCP/IP Address**

The TCP/IP address of the receiver serves as its identification number for the network. Once the receiver is set up properly on a network, it will host a website which can be loaded by typing its IP address into any standard web browser. Therefore the ability to specify a static IP address for the receiver may be useful. To view and modify the IP address, refer to section 4.2.2.1.

## 5.4 Assigning a Subnet Mask

The subnet mask is used to determine where the network number in an IP address ends and the node number in an IP address begins. A node is any device on a network that needs a unique IP address to communicate (computer, server, router, PRO4 Receiver, etc.). To set this value for your purposes, refer to section 4.2.2.1.

## 5.5 Assigning a Default Gateway

A *gateway* refers to a router or host which grants access to the internet. If you have not enabled DHCP, you must specify the TCP/IP address of this default gateway. To set this value, refer to section 4.2.2.1.

## 5.6 Proxy Server Configuration

If you wish to specify a proxy server for your receiver to route through, this must be done using the receiver's command prompt interface. To set this interface up, refer to section 8.1. To modify the proxy server, refer to the E0/E1 PROXY commands in section 8.2.

## 5.7 DNS Server Configuration

The DNS Server settings must be configured using the command interface. Instructions for setting this interface up are in section 8.1. A receiver may specify up to three DNS addresses using the E0/E1 DNS commands described in section 8.2.

## 6 RECEIVER WEB INTERFACE

The XDS PRO4 receiver includes an on-board web interface that will publish itself on your local area network once you have followed the steps in Chapter 5. From this web interface you can view most of the receiver's internal settings as well as the contents of the receiver's hard drive. To access this site, simply open a web browser connected to your network and navigate to <http://10.0.0.1> (unless you have manually changed your LAN address to a different value, in which use this new value as the address). When the page loads, you will see a login page. Once you have logged in, you will see three buttons on the left labeled: *General*, *Programming*, and *Content*. After logging in, you are viewing the information underneath the *General* button by default. Each of these buttons offers a different set of options which are represented as tabs at the top of the screen.

### 6.1 The General Menu

The General menu lists most of the basic receiver attributes and settings. After logging in, you start in the General menu by default. The tabs listed across the top for the General menu are: *Status*, *Tuner*, *Setup*, and *Relays*. The Status tab is the tab displayed by default upon entering the General menu. To navigate to another tab within a menu, simply click the tab's name.

#### 6.1.1 The Status Tab

The Status Tab displays basic attributes about its current output, its surroundings, errors, and current power levels. On this tab you will see:

- A description of the Headphones output including Program, PID, and the volume.
- A list of current faults affecting the receiver, as well as a history of past faults complete with a clear button to wipe the slate clean.
- A run-down of environmental factors including the receiver's internal temperature and fan speed, which is a measure of how hard the receiver is working to cool itself.
- A diagnostic of the power supply's voltage levels. Ideally, the actual voltage matches each of the named levels in each row.

Below is an actual image of the Status Tab. Your broadcaster's logo may appear in the top left corner. Notice the tabs along the top (and that the Status tab is the one currently selected). Also notice the buttons on the side of the page, which will take you to a different set of tabs if clicked.

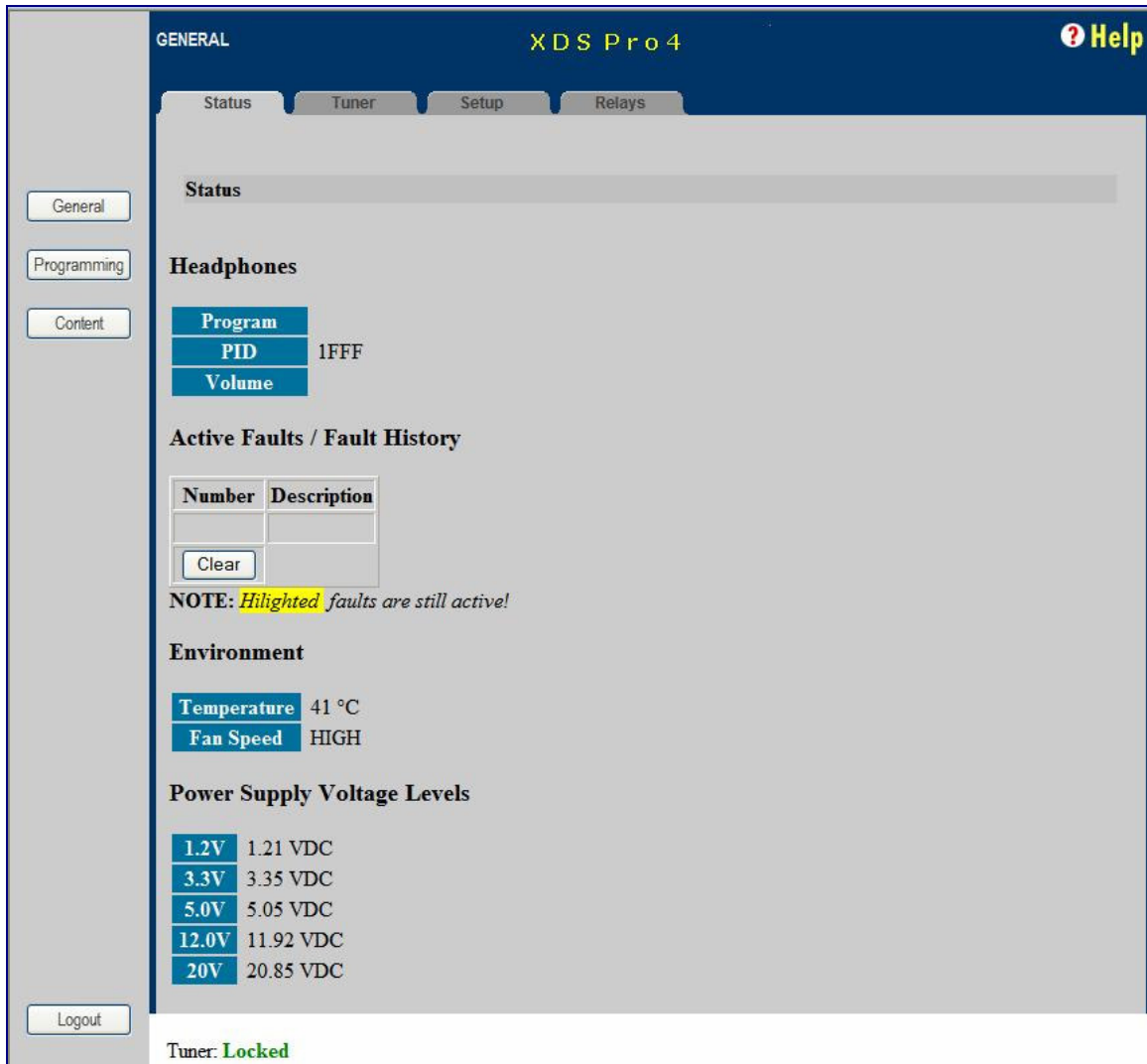

## 6.1.2 The Tuner Tab

The Tuner Tab presents the user with tuner related data. This data include:

- The frequency the tuner is tuned to.
- The tuner's symbol rate.
- The locked or unlocked status of the tuner.
- The acquisition state of the tuner: acquiring, tracking, or fade.
- Eb/No, or *energy per bit relative to noise floor* (see section 4.2).
- AGC, or *automatic gain control* (see section 4.2).
- Fade count of the tuner.
- The number of Reed-Solomon errors that the tuner has encountered.
- The LNB offset the tuner is currently using.
- The on or off status off the LNB.

The fade count and Reed-Solomon errors can be reset by pressing the Clear Statistics button.

Below is an image of the tuner tab.

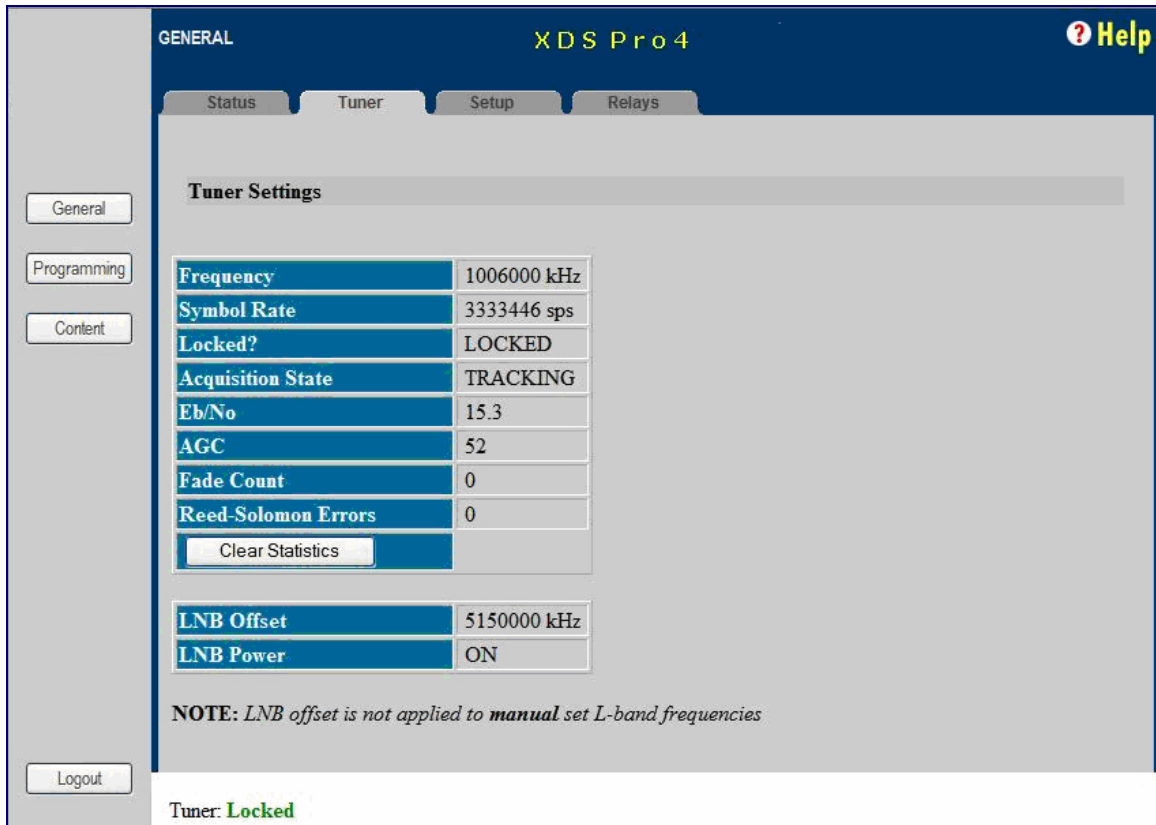

### 6.1.3 The Setup Tab

The Setup Tab shows even more detailed and specific receiver facts:

- The receiver's serial number.
- The receiver's addressing value.
- The receiver's firmware version.
- The date that the current receiver's firmware was designed.
- Station assignments for each of the four audio ports (i.e. station call numbers).
- Networking values used by the receiver including: LAN IP Address, LAN Subnet Mask, Gateway, WAN IP Address, WAN Subnet Mask, primary NMS website URL, and backup NMS website URL.
- Miscellaneous information including data about the serial ports and their settings, and the current hexadecimal alarm mask.

An image of the Setup Tab follows.

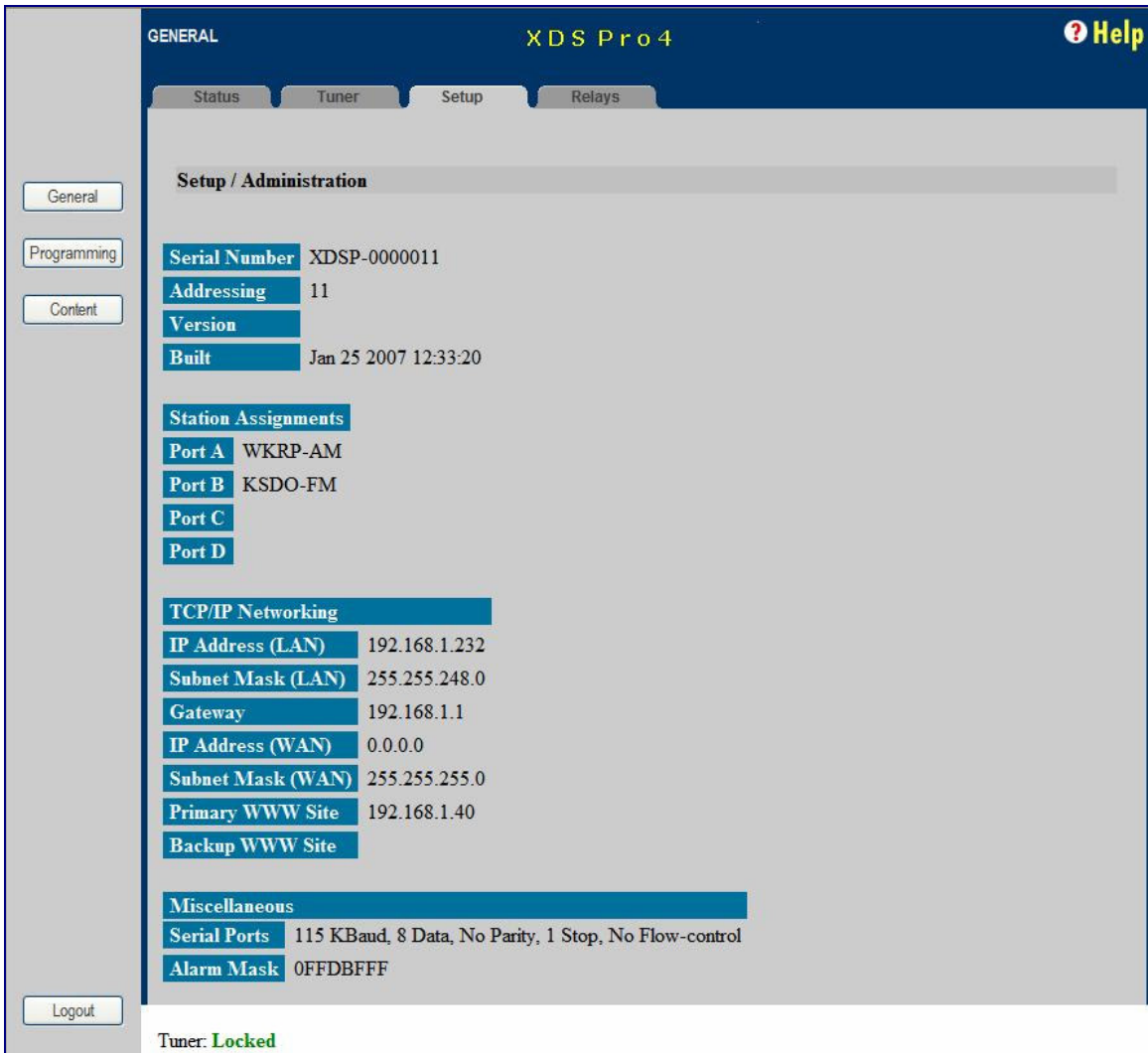

## 6.1.4 The Relays Tab

The Relays Tab lists all the 16 relay mappings complete with their net-cues and on/off status for each of the two relay ports. Thus there are 32 total relays listed, 16 for each the top and bottom relay ports.

Below is an image of the Relays Tab.



## 6.2 The Programming Menu

From the Programming Menu, the user is able to view all of the programs and recordings the receiver is equipped to receive and re-broadcast.

### 6.2.1 The Programs Tab

Each receiver is identified by the Network Management System as authorized to receive and broadcast particular radio programs and as being part of certain airing networks. From this tab, you can see which programs the receiver is set-up to receive and use. In the Programs grid, you are given the Program Name, Code, Mono/Stereo Setting, Program ID (PID), Authorization status, and Status for each Program on the receiver. In the Airing Networks grid you see each Network the receiver may belong to and whether it is currently authorized for this particular network.

Below is an image of the programs tab.



## 6.2.2 The Recordings Tab

In the Recording Tab, every program which has been stored on the receiver's internal hard drive is listed. For each recording, you are given a link to download the recording to your computer's local hard drive, the date that it was recorded, and the length of the recording.



## 6.3 The Content Menu

The Content Menu lists all of the files which the receiver's internal storage currently holds.

### 6.3.1 The Audio Tab

The Audio Tab displays all audio type files which have been stored for later use by the receiver. The file name (along with download link), ISCI code, received date, file size/duration and buttons to delete(X) or play(▶) are displayed for each file.

The audio, traffic and all tabs will all have the same layout. To see an example of what these tabs will look like, view section 6.3.3, *The All Tab*.

### 6.3.2 The Traffic Tab

The Traffic Tab shows all traffic related text or document files. These files will most likely include instruction from network managers, spot related information, or other read-me files.



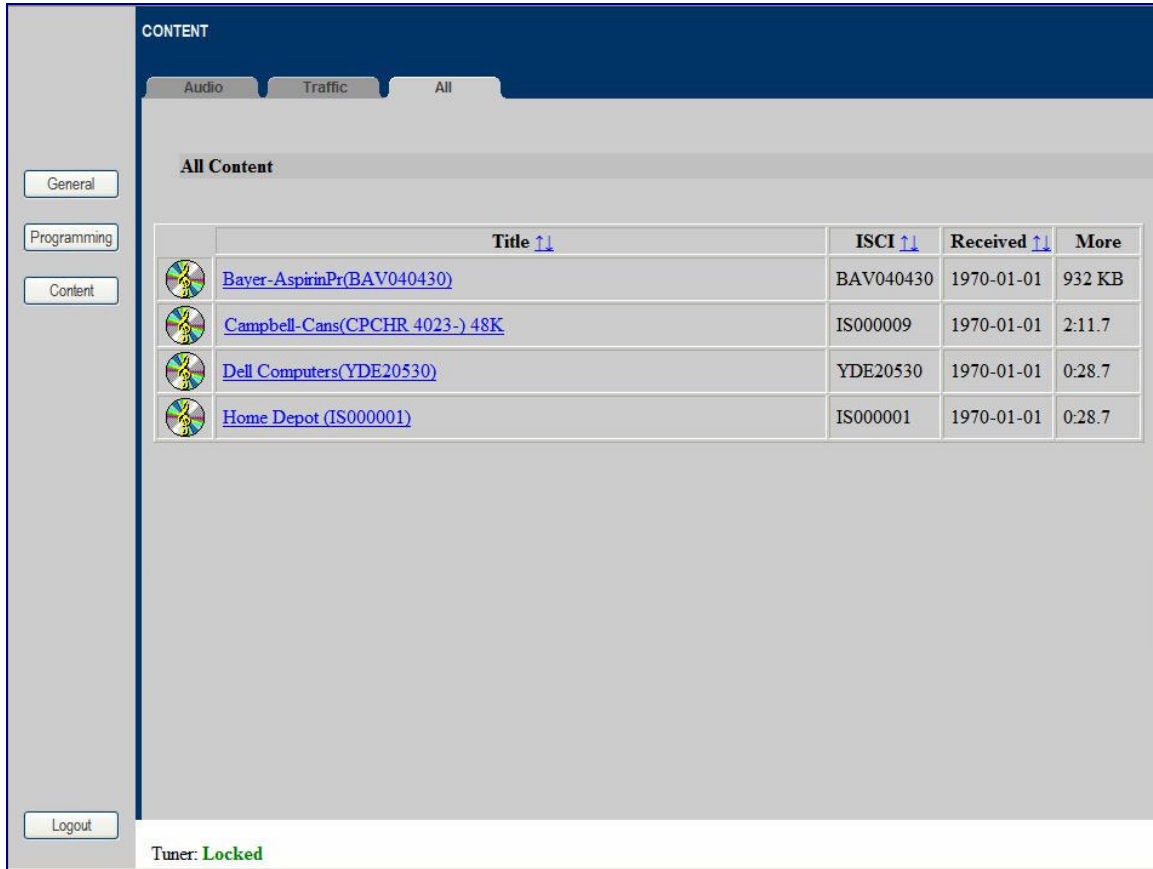

### 6.3.3 The All Tab

The All Tab simply displays all files which the receiver is currently storing.

Here is what the Content tabs look like:



The screenshot shows a web interface for managing content. At the top, there's a dark blue header with the word "CONTENT" in white. Below the header, there are three tabs: "Audio", "Traffic", and "All", with "All" being the active tab. The main area is titled "All Content" and contains a table with four columns: "Title", "ISCI", "Received", and "More". Each row in the table has a small CD icon to the left of the title. The table lists four items: "Bayer-AspirinPr(BAV040430)", "Campbell-Cans(CPCHR 4023-) 48K", "Dell Computers(YDE20530)", and "Home Depot (IS000001)".

	Title <a href="#">↑↓</a>	ISCI <a href="#">↑↓</a>	Received <a href="#">↑↓</a>	More
	<a href="#">Bayer-AspirinPr(BAV040430)</a>	BAV040430	1970-01-01	932 KB
	<a href="#">Campbell-Cans(CPCHR 4023-) 48K</a>	IS000009	1970-01-01	2:11.7
	<a href="#">Dell Computers(YDE20530)</a>	YDE20530	1970-01-01	0:28.7
	<a href="#">Home Depot (IS000001)</a>	IS000001	1970-01-01	0:28.7

On the left side of the interface, there are three buttons: "General", "Programming", and "Content". At the bottom left, there is a "Logout" button. At the bottom center, the text "Tuner: Locked" is displayed in green.

## 7 AFFILIATE WEB INTERFACE

The XDS PRO4 Satellite Receiver is capable of communicating with and being controlled by an external web application called the Network Management System. The NMS is capable of many features which greatly simplify the management of a radio station. Network managers can now automate much of the work that previously had to be done manually on a station to station basis. Creation of a station schedule must be done through the NMS. Additionally, a radio station user of the NMS may modify the relay mappings on the receiver to specify which relays corresponds to which net-cue. The following sections will instruct you on how to accomplish these tasks.

### 7.1 Accessing and Logging In

The website hosting your affiliate web page is provided by your broadcaster. Please refer to the [Quick Start Guide](#) for instructions on navigating to this site.

After the page has loaded, type the username, which is your receiver's serial number (available on the back panel of your receiver and via the front panel display) and password, which is given by navigating to the 'XDS PRO4:Setup:Your Account' submenu in the receiver's front panel display (see section 4.2.2 for more details). Once your correct username and password are typed in, press login.

### 7.2 Play Scheduling

The NMS is a powerful tool for managing your radio network. From the NMS, it is possible to create a play schedule for your receiver. To create a station schedule follow these steps:

- Log into the NMS (see section 7.1).
- On the navigation bar on the top of the page, click "Station Schedules".
- Once the page loads, you should see a grid of the current station schedule for this week. If your Affiliate login and password are authorized for multiple stations, there will be a drop-down menu at the top of the page listing multiple stations, each with different station schedules to edit. Select the station you wish to edit.
- Once you are viewing the station schedule which you wish to edit, ensure that you are viewing the week you wish to edit. The week is listed in the upper right above the schedule grid. If you wish to edit a different week use the arrow links to navigate forwards or backwards in time.
- Once you are view the correct station schedule and the correct week, you are ready to modify the schedule. Click the time on the left had side of the grid that you wish to modify or add a program to.

- If your station is authorized to play any programs, you will now see a drop-down list of programs which you may add to this station schedule. Select the program and live-feed time that you wish to insert into this time slot and click “Next”.
- If you wish to play the program in its entirety, choose this option and click “Next”. If you wish to play only part of the program select this option, and then define which portion of the program you wish to insert by following the instruction. Click “Next”.
- This page allows you to tell the receiver what to do with the feed when it receives it. Playing the program live will not require use of the receiver’s internal hard drive. The other two options will store the program for later use. Click “Next” once you have made your choice.
- On the next page, select the days of the week that you wish to play this program. Only days which this program is broadcast will be available for selection. If this program is to be recurring, do not select an end date. Click “Next”.
- Confirm that all of your settings for this program are correct and click “Finish”.

To delete or modify an already existing program on the schedule, click that program’s name. There is a delete link in the bottom right. You may also click previous to change any of the program’s settings.

## 7.3 Changing the Relay Mappings

There are 32 different relays on the PRO4 receiver, and each of these relays can correspond to a different net-cue for a radio broadcast. You can use the NMS to specify the relay mapping for the receiver. To do this

- Click Relay Mappings at the top of the page beneath the X-Digital Systems logo.
- Select the correct receiver from the receiver S/N drop-down list.
- Click the “Edit” button in the bottom right.
- Edit the text for the corresponding relay you wish to change.
- When done changing relays, press “Save”.
- To cancel the changes you have made and to go back to the previous relay mapping, click “Cancel”.



### Note!

Net-cues entered into the NMS’s relay-mappings text box must be upper-case alphanumeric, i.e. only upper-case letters, or numbers.

## 7.4 Changing the Receiver’s Time Zone

Using the Affiliate website it is also possible to change the receiver’s time zone settings. To do this, navigate to the Home page and select the appropriate time zone from the drop

down list. If you would like to observe daylight savings time, indicate this using the check box provided. To commit changes, click the update button.

## 8 MONITOR AND CONTROL INTERFACE

The PRO4 Receiver is equipped with multiple methods for viewing and changing receiver settings. The M&C Console Port on the back of the receiver can be used for this purpose.

### 8.1 Setting up a Console Connection

To set up a console interface from your computer to the receiver:

- Connect a standard serial cable from the serial port on your computer to the port labeled “Console” on the back of the receiver.
- Open HyperTerminal from the Start Menu: Start > All Programs > Accessories > Communication > HyperTerminal.
- In the Connection Description dialog, enter “XDS PRO4 Console” as the connection Name, and select a connection Logo. Press “OK”.
- In the Connect To dialog, select “COM1” in the Connect using drop down list.



**Note!**

If you have connected the serial cable to a different port rather than COM1, select that port instead.

- In the COM1 Properties dialog, select 115200 in the “Bits per second” drop-down list, 8 in the “Data bits” drop-down list, “None” in the “Parity” drop down list, 1 in the “Stop bits” drop-down list, and Hardware in the “Flow control” drop down list. Press “Apply” and then press “OK”.

You are now ready to communicate with the PRO4 Receiver via the console you have created. There are a variety of typed commands that the receiver responds to. By default the console is not logged into the receiver, and as such the console will have a very limited set of commands to use. Without logging in, the user can only use status commands and may not change any receiver settings. To log in, use one of these two accounts:

- user/guest: the user account has a permission to change standard receiver settings like program ID, monitoring settings, and volume settings.
- tech/ radio: the tech account has full access to every command the receiver has to offer. Only use the account when trouble-shooting the receiver or performing technical diagnostics.

To log into either of these use the LOGIN command, detailed below in section 8.2.

## 8.2 Console Commands

Tasks are performed through the console via commands. The syntax for any command is the name of the command, followed by a comma separated list of one or more option command arguments. Below is a list of all commands available along what command arguments are required and what the command does.

**The ALARM Command:** The ALARM command tells you, and allows you to change, the current ALARM mask the receiver is using. To see the current ALARM mask without modifying it, simple type ALARM without an argument following it. To change the alarm mask, type: ALARM <MASK>, where <MASK> is a hexadecimal digit in the range [0-FFFFFFFF]. Anything larger than FFFFFFFF will be interpreted as the largest mask, FFFFFFFF. This command is only available to the tech profile.

**The E0 and E1 Commands:** The E0 and E1 commands change various settings for the first and second Ethernet ports respectively. The command followed by any of the below options will display that parameter if there is no argument given, or change that parameter to the argument if an argument is given.

Option	Argument	Action
SHOW		Shows various technical data regarding the specified port.
MAC		Same as the SHOW option.
DHCP	,[ON/OFF]	Sets DHCP to ON or OFF depending on the argument.
ADDR	,[a.b.c.d]	Sets the Ethernet port's address to argument.
MASK	,[a.b.c.d]	Sets the Ethernet port's subnet mask to the argument.
PROXY	,[a.b.c.d]:PORT	Sets the Ethernet port's proxy address and port.
DNS	,[a.b.c.d],...	Sets the Ethernet port's DNS servers. One to three DNS addresses can be specified in a coma delimited list.
GATEWAY	,[a.b.c.d]	Sets the Ethernet port's gateway to the argument.
WWW	,[a.b.c.d],[w,x,y,z]	Sets the Ethernet's primary URL to the first argument, and sets the secondary URL to the second argument.

**Table 2. E0 or E1 Command Parameters**

These commands are available to the tech and user profile.

**The FACTORY Command:** This command will reset all of the receiver's settings to factory defaults. The syntax is FACTORY DEFAULTS, [USER/FULL] where USER will reset basic settings to factory defaults and FULL will additionally reset Ethernet and Tuner parameters. Using this command will require a receiver restart.

This command is only available to the tech profile.

**The HELP Command:** This command prints all of the commands available to the current profile. There are no options for this command. This command is available to all profiles.

**The LOGS Command:** This command deals with the receiver's internal logs. There are three possible options to be used with this command:

- **SHOW:** This option will display the receivers log file to the console screen.
- **PURGE:** This option will purge the receivers log and start over with a clean slate.
- **MSG, "message":** This option will place a message in the log file with whatever text is enclosed in the quotes of the argument of this command. The argument is required. This command is only available to the tech profile.

**The LOGIN Command:** This command will log the console into a user profile specified by the parameters. The syntax is: LOGIN [username],[password]. The username and password must match for the login to be successful. The two default argument combinations for the user and tech profiles are "user,guest" and "tech,radio" respectively. This command is available to all profiles.

**The LOGOUT Command:** This command will log the console out of whichever user profile is currently logged in. Remember to LOGOUT each time you are done using the console to change receiver settings.



**Note!**

Logins from previous console sessions stay active until another LOGIN command over-rides the past one or the LOGOUT command is used. For security, LOGOUT when you are done with the console.

**The PING Command:** This command will attempt to ping the IP address specified by the argument. The syntax is: PING [a.b.c.d] where [a.b.c.d] is the IP to ping. The IP is a required argument. This command is a good way to test if your network connection is set up correctly. This command is available to the user and tech profiles.

**The QUIT Command:** This command does the exact same thing as LOGOUT. There are no options for this command and it is available to all profiles.

**The SF Command:** This command displays the fault history. See the SS command for a table of what the fault codes mean. This command is available to all profiles.

**The SN Command:** This command displays the receiver's serial number. It takes no options. This command is available to all profiles.

**The SS Command:** This command displays the current status of the receiver in the form a list of current faults which are affecting the receiver. There are no options for this command. Below is a table which will help to interpret the binary code given by the receiver:

Error Value	Error Name
0x00000001	FPGA Load Error
0x00000002	DSP Load Error
0x00000004	Ethernet Failure
0x00000008	No Storage Device
0x00000010	Tuner Not Locked
0x00000020	<i>reserved</i>
0x00000040	<i>reserved</i>
0x00000080	<i>reserved</i>
0x00000100	<i>reserved</i>
0x00000200	<i>reserved</i>
0x00000400	<i>reserved</i>
0x00000800	<i>reserved</i>
0x00001000	NV Config. Bad
0x00002000	<i>reserved</i>
0x00004000	DSP Timeout
0x00008000	Fan Stopped

Error Value	Error Name
0x00010000	Recorder Overflow
0x00020000	Temp Warning
0x00040000	Temp Critical
0x00080000	<i>reserved</i>
0x00100000	<i>reserved</i>
0x00200000	<i>reserved</i>
0x00400000	<i>reserved</i>
0x00800000	LNB Over-current
0x01000000	<i>reserved</i>
0x02000000	<i>reserved</i>
0x04000000	<i>reserved</i>
0x08000000	URL Event Overflow
0x10000000	Internet Down
0x20000000	Storage Full
0x40000000	SW Download Rdy
0x80000000	SW Download Err.

Table 3. SS and SF Error Code Values

This command is available to all profiles.

**The TIME Command:** This command deals with displaying and setting the internal clock of the receiver. Simply typing TIME without any option will display the time according to the receiver. Time is synchronized automatically with the satellite. Your timezone may be set from the Affiliate webpage.

**The TRACE Command:** This command is used for diagnostic checks of the serial ports. It is available only to the tech profile.

**The TUNER Command:** This command is used to view and modify all of the receiver's tuner settings. Typing this command without any options will display a useful usage message. Type this command followed by one of these options/argument combinations to view or modify tuner settings:

Option	Argument	Action
SHOW		Shows various technical data regarding the specified port.
SET	,[kHz],[sps]	Sets the tuners radio frequency to [kHz] and the tuner's symbol rate to [sps].
LNB	,[kHz]	Sets the tuner's LNB offset to [kHz].
SR	,[sps]	Sets the tuner's symbol rate to [sps].
LNBV	[ON/OFF]	Sets LNBV to ON or OFF depending on argument.
CLEAR		Clears all tuner statistics.

#### Table 4. Tuner Command Parameters

**The VER Command:** This command, which takes no options, simply displays the receiver's firmware version to the console. This command is available to all profiles.

**The VOL Command:** This command sets the volume of the receiver's headphone output. The syntax is: VOL [v] where [v] is a value greater than or equal to 0 (mute) and less than or equal to 63 (full volume). This command is available to the tech and user profiles.

## 9 SPECIFICATIONS

The following specifications are divided into sections corresponding to the various functional blocks within the receiver.

### 9.1 Receiver Interface Specification

LCD	image display capability, backlighting
Keypad	full 8 key-pad, menu buttons, arrow keys, enter key
Status LEDs	power, signal, update, and fault indications
Monitor and Control Interface	RS-232C compatible, DB-9 female
Web Interface	automatically broadcast via LAN and WAN

Table 5. Interface Specifications

### 9.2 Mechanical/Electrical Specification

Dimensions	3.5" x 18" x 12"
Mounting	19", 2RU
Weight	8 lbs
Input Voltage	90 – 240 VAC (50/60 Hz)
Power Consumption	65 W maximum

Table 6. Mechanical and Electrical Specifications

### 9.3 Environmental Specifications

The power supply will be a 65W universal input switching power supply that is UL safety rated. We expect the system to operate without a need for a fan in air conditioned locations. The fan will be electronically controlled via temperature sensor. This will allow the unit to operate under less than optimal conditions.

## 9.4 M&C Interface Connector Pin-Outs

The Monitor and Control (M&C) port allows basic configuration of the XDS receiver via an asynchronous RS232C electrical interface. It uses the following protocol settings: 115.2K baud, 8 data bits, No Parity, 1 stop bits, and no hardware flow control. In addition to the asynchronous interface, the M&C connector provides a status relay output and four optical inputs. The four optical inputs are activated grounding the input signal. The following table provides the pin-out for the M&C port.

PIN	FUNCTION
1	Ground
2	TX
3	RX
4	ALARM
5	Ground
6	OPTO1
7	OPTO2
8	OPTO3
9	OPTO4

**Table 7. M&C Port Pin-Out**

Connection	DB-9F
Asynchronous Port	115.2K baud, 8 data bits, no parity, no hardware flow control
Relay Format	1 Form A
Optical Inputs	4 Input Signals, Connect to ground to activate

**Table 8. M&C Port**

## 9.5 Relay Outputs

There are two DB-37 connectors on the rear panel which together contain a total of 32 mappable relay (or contact) closures. The following tables provide the pin-outs for the two relay connectors.

PIN	FUNCTION	PIN	FUNCTION
1	RLY1A	20	RLY1B
2	RLY2A	21	RLY2B
3	RLY3A	22	RLY3B
4	RLY4A	23	RLY4B
5	Ground	24	Ground
6	RLY5A	25	RLY5B
7	RLY6A	26	RLY6B
8	RLY7A	27	RLY7B
9	RLY8A	28	RLY8B
10	Ground	29	RLY9B
11	RLY9A	30	RLY10B
12	RLY10A	31	RLY11B
13	RLY11A	32	RLY12B
14	RLY12A	33	Ground
15	NQ TxData	34	RLY13B
16	RLY13A	35	RLY14B
17	RLY14A	36	RLY15B
18	RLY15A	37	RLY16B
19	RLY16A		

Table 9. Relay Port A Pin-Out

PIN	FUNCTION	PIN	FUNCTION
1	RLY1A	20	RLY1B
2	RLY2A	21	RLY2B
3	RLY3A	22	RLY3B
4	RLY4A	23	RLY4B
5	Ground	24	Ground
6	RLY5A	25	RLY5B
7	RLY6A	26	RLY6B
8	RLY7A	27	RLY7B
9	RLY8A	28	RLY8B
10	Ground	29	RLY9B
11	RLY9A	30	RLY10B
12	RLY10A	31	RLY11B
13	RLY11A	32	RLY12B
14	RLY12A	33	Ground
15	Ground	34	RLY13B
16	RLY13A	35	RLY14B
17	RLY14A	36	RLY15B
18	RLY15A	37	RLY16B
19	RLY16A		

Table 10. Relay Port B Pin-Out

Connection	DB-37M
Contacts	16 Relays
Format	Form A

Table 11. Relay Outputs

## 9.6 Analog Audio Output

The receiver has four analog audio output ports. The following table has the pin-outs of the analog output ports.

PIN	FUNCTION
1	L OUT+
2	Ground
3	LOUT+
4	Ground
5	R OUT+
6	L OUT-
7	Ground
8	LOUT-
9	R OUT-

Table 12. Analog Audio Output Pin-out

Connection	DB-9M
Format	Balanced Pair L, R
Range	-10 to +4dBu nominal (+22 max)
Performance	0.1% THD 85dB dynamic range

**Table 13. Analog Audio Output**

## 9.7 Analog Audio Input

The receiver has one analog audio input port. The following table has the pin-out of the analog input port.

PIN	FUNCTION
1	L IN+
2	Ground
3	Not Connected
4	Ground
5	R IN+
6	L IN-
7	Ground
8	Not Connected
9	R IN-

**Table 14. Analog Audio Input Pin-out**

Connection	DB-9M
Format	Balanced Pair L, R
Range	+4dBu nominal (+22max)

**Table 15. Analog Audio Input**

## 9.8 Digital Audio Output

The receiver has a single digital audio output port that provides AES/EBU versions of the first two analog audio ports (Ports A and B). The Port A audio is located on the pair of CH0 signals while the Port B audio is located on the pair of CH1 signals. The following table contains the pin-out of the digital audio port.

PIN	FUNCTION
1	CH0_TX+
2	Ground
3	Not Connected
4	Ground
5	CH1_TX+
6	CH0_TX-
7	Not Connected
8	Not Connected
9	CH1_TX-

Table 16. Digital Audio Output Pin-out

Connection	DB-9M
Format	Balanced AES/EBU

Table 17. Digital Audio Output

## 9.9 PAD/ASYNC Output Port

The PAD port (Program Associated Data) relays information which is carried along with the audio data received. I.e. song and artist information, or relay queues to trigger events. Below is a pin-out table for the PAD port.

PIN	FUNCTION
1	P0_TX
2	P1_TX
3	P2_TX
4	P3_TX
5	Not Connected
6	Ground
7	Ground
8	Ground
9	Ground

Table 18. PAD/ASYNC Output Port Pin-out

Connection	DB-9F
Asynchronous Port	variable up to 115.2K baud, 8 data bits, no parity, no hardware flow control

Table 19. PAD/ASYNC Port

## 9.10 Ethernet Port

Connection	RJ-45
Connection Rate	10/100Base-TX (Auto)
Number of Ports	3 external, 1 internal
Max Output IP Rate	Up to 20 Mbps (combined for all ports)
VLAN	Each port is managed for VLAN use

## 9.11 Modem (POTS) Port

Connection	RJ-11
Connection Rate	14.4L, 28.8L, 56k
Format	8Bits, No parity, One Stop

## 9.12 RF Input Parameters

Data will be demodulated and then de-multiplexed by PID (Program ID). On demand, the de-multiplexed data will be transmitted via the Ethernet switch to any of the devices requesting such data.

Connection	75 ohm F-type connector
Frequency Input Range	950 to 2150 MHz
Input Level	-65dBm to -25dBm
Symbol rate	2 to 40 Msps
Modulation Scheme	QPSK
Forward Error Correction modes	Reed-Solomon and Viterbi (DVB-S)
LNB Power	20VDC 500mA MAX